

INSTRUCTION, BUS INSTALLATION (WL) P/N 266995-01



CARRIAGE SCREW,
SQUARE NECK
3/8"-16 X 4" LG.
GRADE 5, ZINC PLATED
P/N 900063-12
QTY. 10



CARRIAGE SCREW,
SQUARE NECK
3/8"-16 X 6" LG.
GRADE 5, ZINC PLATED
P/N 900063-16
QTY. 8



CARRIAGE SCREW,
SQUARE NECK
3/8"-16 X 8" LG.
GRADE 5, ZINC PLATED
P/N 900063-17
QTY. 2



CAP SCREW, HEX
HEAD, 3/8"-16 X 4" LG.
GRADE 8, ZINC PLATED
P/N 900014-14
QTY. 10



CAP SCREW, HEX
HEAD, 3/8"-16 X 1" LG.
GRADE 8, ZINC PLATED
P/N 900014-4
QTY. 1



SCREW, #12
SELF DRILLING, HEX
WASHER HEAD
P/N 900045-1
QTY. 2



FLAT WASHER, 7/16",
ZINC PLATED
P/N 906480-01
QTY. 6



FLAT WASHER (SHIM)
3/8" X 1/16" THICK
P/N 902001-2
QTY. 8



FLAT WASHER (SHIM)
3/8" X 1/8" THICK
P/N 902001-1
QTY. 20



LOCK WASHER, 3/8"
P/N 902005-1
QTY. 11



LOCK NUT, 3/8"-16
GRADE 8, ZINC PLATED
P/N 901002
QTY. 10



NUT, HEX HEAD, 3/8"-16
GRADE 8, ZINC PLATED
P/N 901011-5
QTY. 1

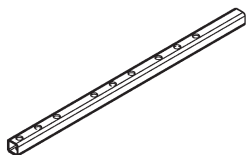

TUBE, INSTALLATION
P/N 266994-01
QTY. 5

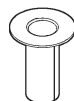

GROMMET, 1"
P/N 267066-01
QTY. 1



PLASTIC TIE, 7"
P/N 205780
QTY. 3

MOUNTING THE LIFT

NOTE: Lift installation is not complete until the following instructions and all the instructions in the Installation Manual are completed. See **MP-04-01 for the WL7**, **MP-05-10 for the WL7A**, **MP-06-01 for the WL7-vers. B** and **MP-06-09 for the WL7-vers. C**. The following steps are the instructions for bolting the Lift to a bus floor with the correct screws, nuts, washers, and under-vehicle supports.

NOTE: **MAXON** recommends using all 10 carriage screws or cap screws (Kit items) to bolt Lift to vehicle. At least 8 carriage screws or cap screws and use of holes 1, 2, 3, 4 & 9 are required for correct installation. Also, the front 3 holes should be selected to give a symmetrical bolt pattern (i.e. holes 5,10, & 8 or holes 6,10, & 7).

1. Drill the remaining holes marked according to instructions in the Installation Manual (i.e. holes 5, 10, & 8 or holes 6,10, & 7). See **MP-04-01 for the WL7**, **MP-05-10 for the WL7A**, **MP-06-01 for the WL7-vers. B** and **MP-06-09 for the WL7-vers. C**. Make sure no wires and fluid lines are too close to hole locations before drilling holes in the vehicle floor.

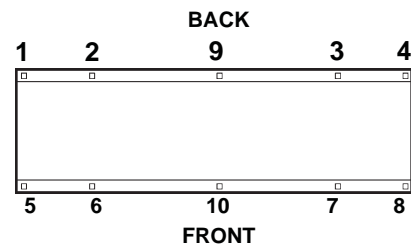

BASE PLATE BOLT HOLE PATTERN
FIG. 2-1

NOTE: Vehicle floor must meet the requirements shown at the beginning of the **VEHICLE REQUIREMENTS** section of the Installation Manual. See **MP-04-01 for the WL7**, **MP-05-10 for the WL7A**, **MP-06-01 for the WL7-vers. B** and **MP-06-09 for the WL7-vers. C**. If possible, use vehicle subframe members to help support installation tubes (**FIG. 2-2A**). If needed, an installation tube can be shortened to fit between vehicle subframe members (**FIG. 2-2A**). However, installation tube must be at least 16" long. Since the installation tubes have holes for bolting to the base plate, do not shorten the end of the tube that has the bolt holes.

2. Insert 3/8"-16 screws through the holes in the base plate (**FIG. 2-2B**), vehicle floor, and support to hold the Lift in position. Use the 4" long, 6" long, or 8" carriage screws, or the 4" long cap screws as required.

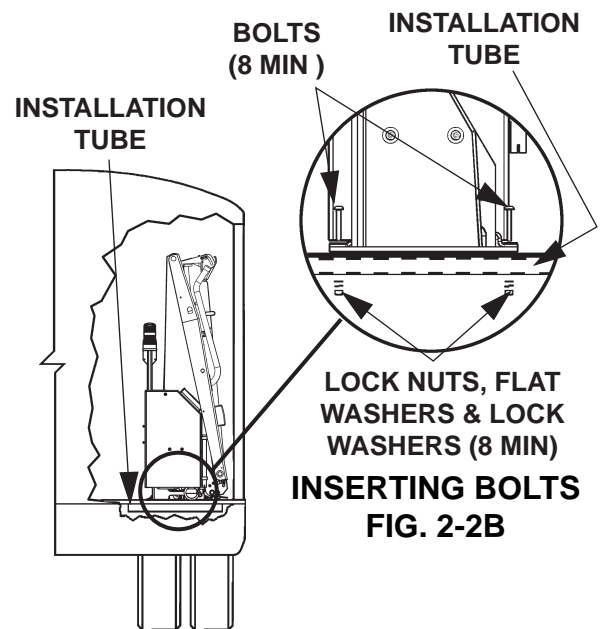

INSERTING BOLTS
FIG. 2-2B

INSTALLATION TUBES
FIG. 2-2A

NOTE: MAXON recommends using all 5 installation tubes (Kit items) to bolt Lift to vehicle. For correct installation, at least 4 installation tubes are required, and each tube must be secured by 2 carriage screws or cap screws. If a screw cannot be secured under the vehicle through an installation tube, a 7/16" wide area washer must be used to secure the screw.

3. Bolt up the installation tubes and spacer plates (if required) to underside of vehicle. Use the carriage screws or cap screws inserted through the base plate (**FIG. 3-1**), flat washers, lock washers, and lock nuts. Refer to **FIGS. 3-1, 3-2, 4-1, and 4-2** for the recommended methods for installing Lift on different vehicle floors.

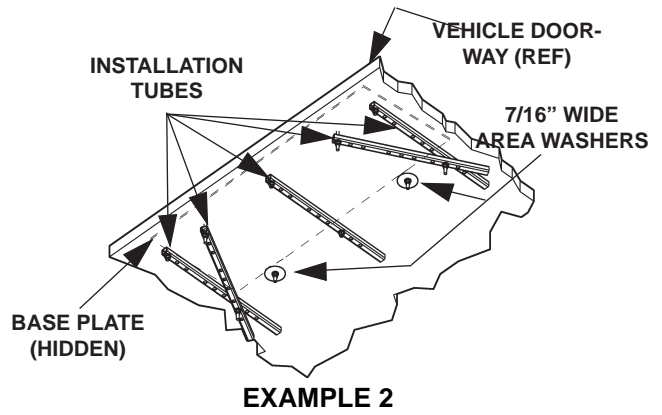
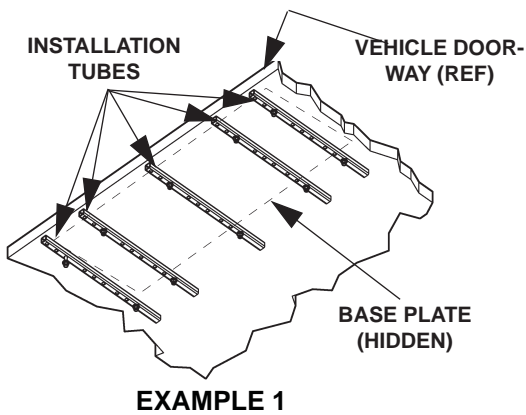

SECURING BASE PLATE WITH INSTALLATION TUBES AND SPACER PLATES (VEHICLE FLOOR BOTTOM VIEW)
FIG. 3-1

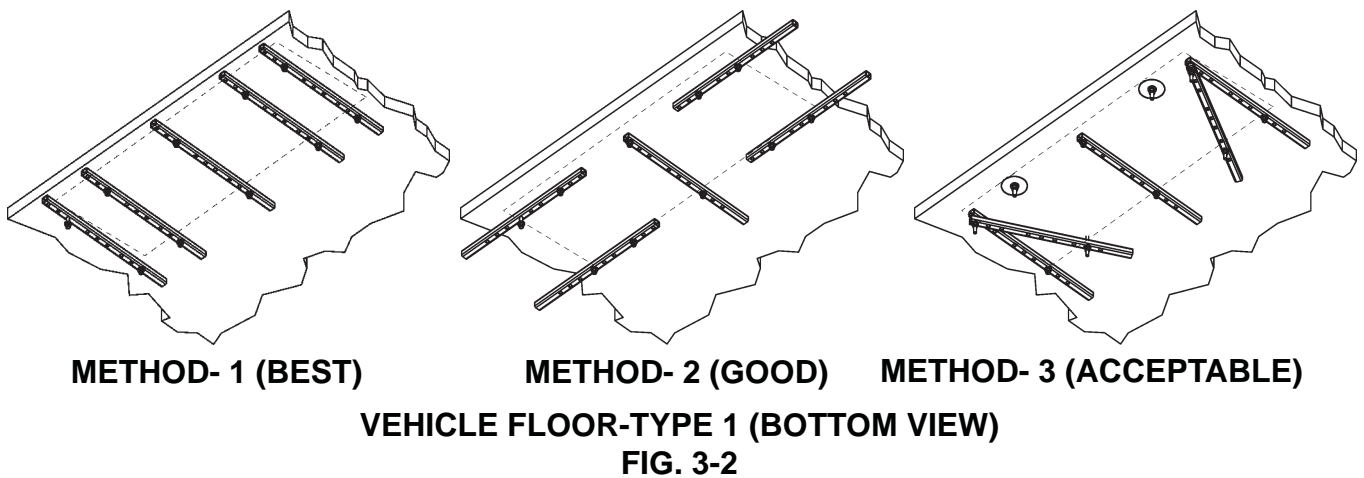

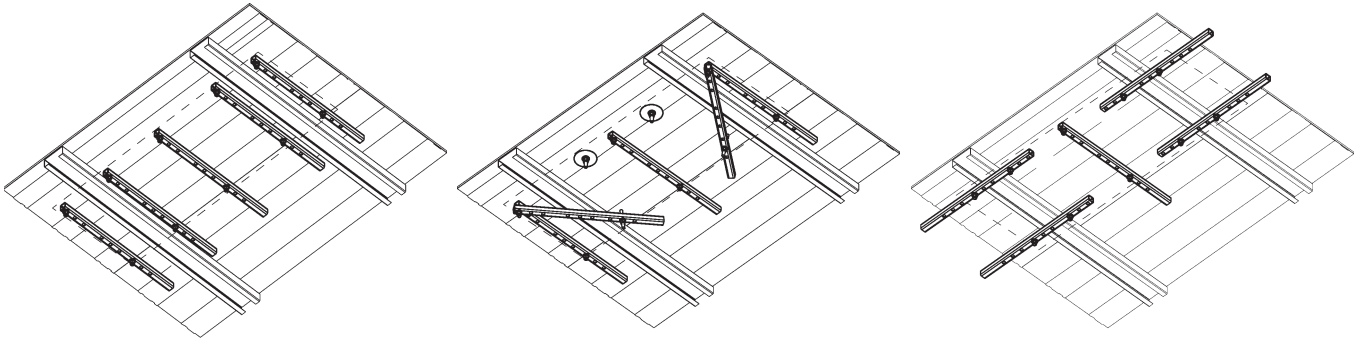

METHOD- 1 (BEST)

METHOD - 2 (GOOD)

METHOD- 3 (ACCEPTABLE)

VEHICLE FLOOR-TYPE 2 (BOTTOM VIEW)

FIG. 4-1

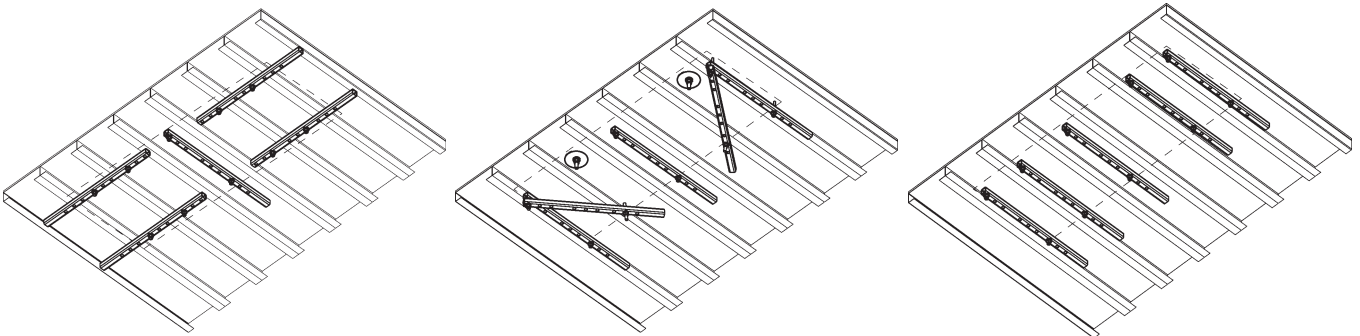

METHOD- 1 (BEST)

METHOD- 2 (GOOD)

**METHOD- 3 (ACCEPTABLE,
EXCEPT FOR PLYWOOD)**

VEHICLE FLOOR-TYPE 3 (BOTTOM VIEW)

FIG. 4-2

⚠ CAUTION

To prevent Lift base assembly from becoming warped, tighten attaching screws in the correct sequence indicated in the following NOTE. Warped base assembly can result in misaligned Lift traveling arms and cause Lift to operate incorrectly (uneven movement).

4. Tighten each of the carriage screws or cap screws and lock nuts in the correct sequence shown in **FIG. 5-1**. Start by tightening screw number 2. If a bolt hole is not used, skip over it in the tightening sequence. Torque each screw to **20 to 30 LBS.-FT.**

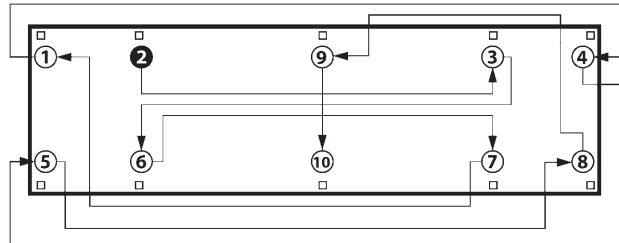

**BASE PLATE BOLT
TIGHTENING SEQUENCE
FIG. 5-1**

5. Check the Lift for correct alignment as follows. Measure angle between RH tower and base plate (**FIG. 5-2**). Repeat for LH tower. Both the RH and LH towers must be approximately at a 90 degree angle to base plate (**FIG. 5-2**). If either tower is not at a 90 degree angle, place shim washer (Kit item) on the affected side of the base plate, between base plate and vehicle floor. Use the existing screws to secure the shim. Retighten screws according to step 4 and the preceding **NOTE**.

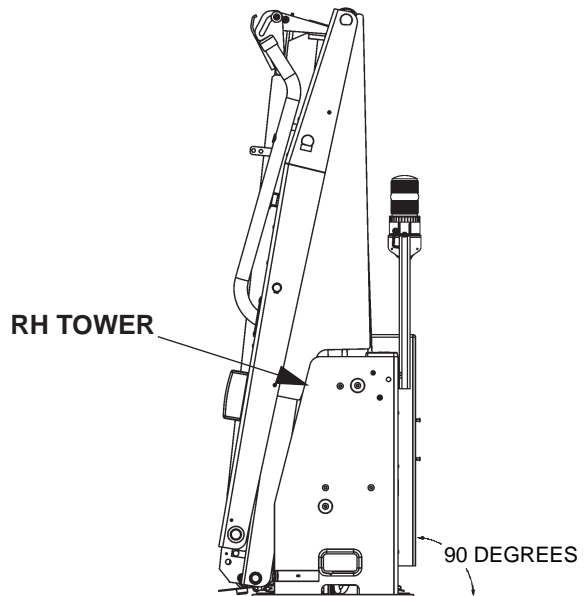

**CORRECT ALIGNMENT
(WL7-vers. C SHOWN)
FIG. 5-2**

6. Check stowed Lift for correct clearance (**FIG. 6-1**) between each vertical arm and platform. If there is too much (**FIG. 6-2**) or too little clearance (**FIG. 6-3**), shim the base plate screws where shown in the applicable figure. Place shim washers (Kit item) between base plate and vehicle floor. Use the existing screws to secure shim. Retighten screws according to step 4 and the preceding **NOTE**.

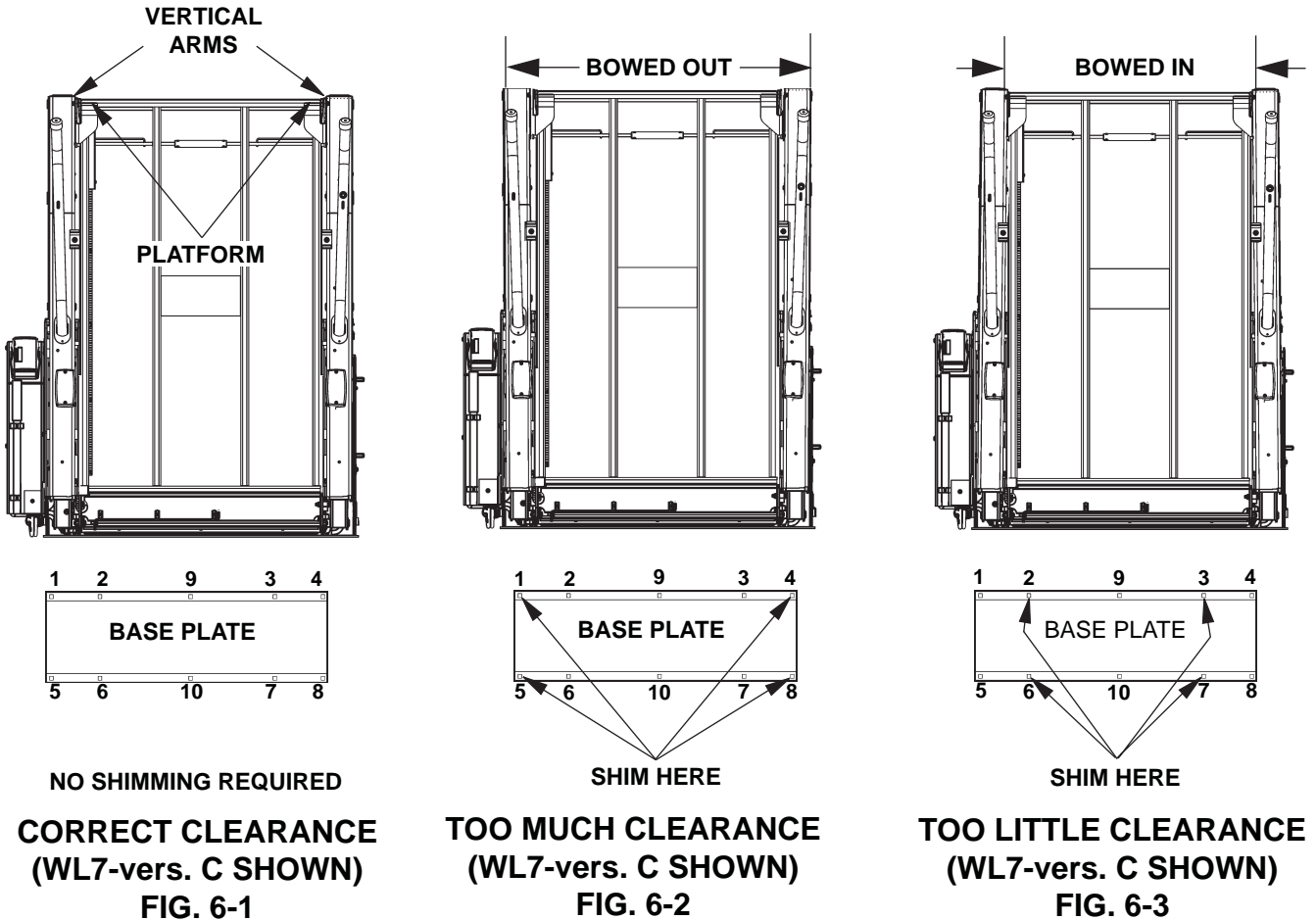

7. For WL7 only, rotate the threshold plate into correct position above the base plate (**FIG. 6-4**).

8. Refer to the Installation Manual to finish the checks, adjustments and **COMPLETED LIFT INSTALLATION CHECKLIST**. See **MP-04-01** for the WL7, **MP-05-10** for the WL7A, **MP-06-01** for the WL7-vers. B and **MP-06-09** for the WL7-vers. C.

